



SQUIB IRISH CHAMPIONSHIP

19th June – 21st June 2015



Howth Yacht Club
Howth, Co. Dublin, Ireland

SAILING INSTRUCTIONS

1. RULES

- 1.1. The event will be governed by the rules as defined in the Racing Rules of Sailing.
- 1.2. The 'National Squib Class Rules' will apply with the exception listed in 1.3 below. In the case of a conflict between the 'National Squib Class Rules' and the Sailing Instructions or the Notice of Race, the 'National Squib Class Rules' will prevail.
- 1.3. Under Rule 87, rules of the National Squib Class are changed as follows:
 - 1.3.1. Class Rule C.10.2. On days when more than one race is scheduled, a replacement spinnaker may be carried on board whilst racing. The second spinnaker shall only be used if the first is lost or damaged beyond repair.
 - 1.3.2. In addition to the safety items required by class rules each competing boat shall carry a suitable compass. This instruction adds to Class Rule C5.1(a).
- 1.4. In the case of conflict between the Sailing Instructions and the Notice of Race these Sailing Instructions will prevail.
- 1.5. The applicable Prescriptions of the Irish Sailing Association to the Rules, which shall apply, are as follows:
 - (i) Rule 46 Person in Charge
To be eligible to compete in any event run by any organisation affiliated to the ISA the designated Person in Charge shall:
 - a) Be a member of a Category One affiliated Club or an individual member of the Irish Sailing Association; or
 - b) When the designated Person in Charge is not ordinarily a resident within the jurisdiction of the Irish Sailing Association the competitor shall comply with the requirements of the National Authority of the country of which he is a national or ordinarily a resident.
 - (ii) Rule 68 Damages
No claims for damages arising from an infringement of any of the rules, as defined, shall be adjudicated upon by any protest committee or appeal authority but shall be subject to the jurisdiction of the courts.
 - (iii) Appendix F Appeals Procedures
A fee of €35 shall be forwarded to the ISA with the appeal documents. This fee may be waived under exceptional circumstances.

2. NOTICES TO COMPETITORS

Notices to competitors will be posted on the official notice board(s) located as described in Addendum 1.1.

3. CHANGES TO SAILING INSTRUCTIONS

Any change to the Sailing Instructions will be posted before 0900 on the day it will take effect, except that any change to schedule of races will be posted by 1900 on the day before it will take effect. Such changes may include bringing forward a race.

4. SIGNALS MADE ASHORE

- 4.1. Signals made ashore will be displayed at the location described in Addendum 1.2.
- 4.2. Flag L; when Flag L is displayed ashore it will be flown only until the warning signal for the first race affected by the relevant notice to competitors.
- 4.3. Flag Y; when Flag Y is displayed ashore, Rule 40 applies at all times while afloat. (This changes the Part 4 preamble.)
- 4.4. When flag AP is displayed ashore “1 minute” is replaced with “not less than 60 minutes” in the race signal AP.

5. SCHEDULE OF RACES

- 5.1. The schedule of races is described in Addendum 1.3
- 5.2. For the purposes of results and awarding prizes, races will be numbered in the order in which they are completed.
- 5.3. A maximum of one extra race per day may be sailed, providing the event becomes no more than one race ahead of schedule and the change is made in accordance with instruction SI 3.
- 5.4. Where more than one race is scheduled on a day the second race will start as soon as possible following the completion of the previous race, Flag W will be displayed during the finishing period to indicate that competitors are requested to stay out on the water.
- 5.5. No warning signal will be made after 1500 on the last scheduled day of racing.

6. CLASS FLAG

The Class Flag is a brown flag with the Squib logo.

7. RACING AREA

Addendum 1.4 shows the location of the racing area.

8. THE COURSES

- 8.1. The Courses to be used and the flags that designate them are described in Addendum 2. This includes the approximate angles between legs, the order in which marks are to be passed, and the side on which each mark is to be left.
- 8.2. No later than the warning signal, the Course to be sailed will be designated by displaying the appropriate flag on the Race Committee Signal Boat.
- 8.3. No later than the warning signal, the approximate compass bearing of the first leg may be displayed on the Race Committee Signal Boat.

9. MARKS

- 9.1. The Marks to be used are described in Addendum 3.
- 9.2. A race committee boat signalling a change of a leg of the course is a mark as provided in instruction 12.4

10. AREAS THAT ARE OBSTRUCTIONS

Areas that are obstructions are described in Addendum 1.6.

11. THE START

- 11.1. Races will be started using Rule 26 with the following addition. For the first attempted start of each race an attention signal (flag G with one sound signal) will be made 5 minutes before the warning signal. Flag G will be removed with one sound signal one minute before the warning signal.
- 11.2. The starting line will be a line between a red/white pole or the main mast displaying an orange flag on the Race Committee Signal Boat and either the:
 - mast displaying an orange flag on a Line Boat (at the port end of the line); or
 - starting mark.
- 11.3. Start line limit marks may be laid near the Race Committee signal boat and the Race Committee line boat. These marks shall rank as starting marks and boats shall pass between them when starting. After the preparatory signal no part of a boat shall pass between the starboard-end limit mark and any part of the Race Committee signal boat or the port-end limit mark and any part of the Race Committee line boat. Failure for these marks to be on the line shall not constitute grounds for redress under rule 62.1(a).
- 11.4. A mid line mark may be laid approximately mid way along the start line. It shall not rank as a starting mark and failure for it to be on the line shall not constitute grounds for redress under rule 62.1(a).
- 11.5. The Race Committee line boat may repeat the visual signals of the Race Committee signal boat, including boats deemed OCS under rule 30.3: The signals of the Race Committee signal boat will govern
- 11.6. The only starting penalty that will be applied is Rule 30.3, the Black Flag Rule. This alters Rule 30. However, the Race Committee may substitute Flag U for the Black Flag. In this case, the following will apply:

If flag U has been displayed as the preparatory signal, no part of a boat's hull, crew or equipment shall be in the triangle formed by the ends of the starting line and the first mark during the last minute before her starting signal. If a boat breaks this rule and is identified, she shall be disqualified without a hearing but not if the race is restarted or resailed or postponed or abandoned before the starting signal. This changes rule 26 Starting Races and RRS 63.1.
- 11.7. Boats disqualified under Rule 30.3 will be notified by displaying their sail numbers on the starboard side of the finishing vessel. In addition, these sail numbers may be displayed by a Race Committee Vessel stationed near Mark 1 and displaying a Black Flag.
 - 11.7.1. If a Black Flag Start is followed by a general recall the sail numbers will be displayed on the Race Committee Boat for at least 5 minutes before the Flag first substitute is lowered prior to the start of the same race, this changes Rule 30.3.

Any boat so notified shall immediately retire and leave the course area unless she is protesting or seeking redress under Rule 62.1.

- 11.7.2. A boat failing to comply with this requirement may be scored DNE for that race and may be disqualified from the series at the discretion of the Protest Committee (adding to Rule 64.1)
- 11.8. When the Race Officer decides that any boat has been materially prejudiced by the application of Rule 30.3 due to an improper action or omission of the Race Officer, it may grant redress without a hearing by not displaying the sail number of the boat(s) concerned. This changes Rule 63.1.
- 11.9. A boat starting later than 5 minutes after her starting signal will be scored DNS. This changes Rule A4.2.

12. CHANGE OF THE POSITION OF THE NEXT MARK

- 12.1 Minor (+ or – 10 degrees, or + or – 100 Metres) changes to the course will not be signalled.
- 12.2 Where significant changes to the course are required the Race Committee will lay a new mark (or move the finishing line) and remove the original mark as soon as practicable. The change will be signalled before the leading boat has begun the leg although the new mark may not yet be in position.
- 12.3 When in a subsequent change a new mark is replaced, it will be replaced by an original mark.
- 12.4 Except at a gate, boats shall pass between the Race Committee Vessel signalling the change of course and the nearby mark leaving the mark to port and the Race Committee Vessel to starboard. This changes to Rule 28.1.

13. THE FINISH

- 13.1. The finishing line will be between a red/white pole or the main mast on the Race Committee Vessel displaying an orange flag and the finishing mark.
- 13.2. When the course is shortened at the leeward mark or gate a Race Committee Vessel will display Flag F in the vicinity of the leeward mark or gate whilst making repetitive sound signals. Boats should leave mark 3 to port and sail directly to the finishing line, which will be signalled by a Finishing Vessel displaying an orange flag and the finishing mark, this adds to Rule 32.2.

Illustration of Shorten Course at Leeward Mark or Gate

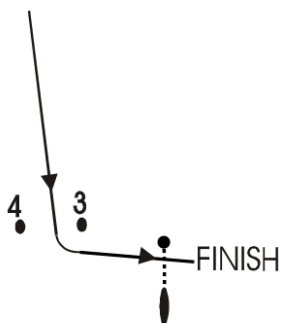

- 13.3. The Race Committee may shorten a course for any reason. No redress can be claimed for such an action. This changes RRS 32 and 62.

14. PENALTY SYSTEM

A boat that has taken a penalty or retired under Rule 31 or Rule 44.1 shall complete an acknowledgment form at the Race Office within the protest time limit.

15. TIME LIMITS

- 15.1. The time limit for races will be two hours (where only one race is scheduled for that day) or 90 minutes (where more than one race is scheduled for that day or where a race is started at or after 1800 hours).
- 15.2. A race will be valid for all those boats finishing within the time limit. This changes Rule 35.
- 15.3. When the first boat finishes within the last hour of the prescribed time limit, the race will be valid for those boats that finish within one hour of the finishing time of the first boat, this changes Rule 35.
- 15.4. Notification of any resail date and time, or cancellation will be posted on the Notice Board as SI 3.
- 15.5. If the first boat has not rounded the first mark of the course within one hour of the starting signal, the race will be abandoned.

16. PROTESTS AND REQUESTS FOR REDRESS

- 16.1. Arbitration will be available.
- 16.2. Protests forms are available at the Race Office.
- 16.3. Boats intending to protest shall inform the Finishing Boat and wait to receive acknowledgment, after having completed that race and before leaving the race area. Such boats should not impede boats racing or the functioning of the Finishing Boat
- 16.4. The protest time limit is 60 minutes after the last boat has finished the last race of the day.
- 16.5. Notices will be posted no later than 15 minutes after the protest time limit to inform competitors of hearings in which they are parties or named as witnesses. Hearings will be held in the protest room located as per the details shown on the Notice Board. The Protest Schedule will be displayed on the Notice Board.
- 16.6. On the last day of scheduled racing, a request for reopening a hearing shall be delivered;
- within the protest time limit if the party requesting reopening was informed of the decision the previous day
 - no later than 30 minutes after the party requesting reopening was informed of the decision on that day.
 - No later than 30 minutes after a signal to abandon racing is displayed ashore.

This changes Rule 62.2 and 66.

17. SCORING

- 17.1. The Low Points scoring system of Appendix A will apply.
- 17.2. When fewer than 4 races have been completed, a boat's series score will be the total of her race scores.
- 17.3. When from 4 to 6 races have been completed, a boat's series score will be the total of her race scores excluding her worst score.
- 17.4. 6 races are scheduled, of which 3 races shall be completed to constitute a series.

18. SAFETY REGULATIONS

- 18.1. In addition to the safety items required by class rules it is strongly recommended that each boat carry on board: a suitable compass and a marine band hand held VHF radio. This instruction adds to Class Rule No. C.5.1.
- 18.2. A boat that retires from a race shall, where possible, notify a Race Committee Vessel on Channel 77 before leaving the racing area and shall immediately on returning to shore comply with 14.1.
- 18.3. Adequate personal flotation devices for each person on board, shall be worn or carried in the boat at all times. Wet suits and dry suits are not adequate personal flotation devices. Competitors' attention is drawn to the significance of displaying IC Flag Y. Competitors clothing shall not weigh more than 10 kilograms, excluding any clothing worn only below the knee and footwear. Weights shall be determined as required by Appendix H. This alters Rule 43.1(b).
- 18.4. Not used

19. REPLACEMENT OF CREW OR EQUIPMENT

- 19.1. Substitution of competitors shall not be allowed without prior written approval of the Race Committee. Permission to substitute crew will only be granted in cases of injury or illness or serious unforeseen personal circumstances.
- 19.2. Substitution of damaged or lost equipment will not be permitted unless authorised by the Race Committee. Requests for equipment substitution shall be made at the first reasonable opportunity
- 19.3. All boats shall sail under their registered class number. Only sails that have been scrutineered for the event shall be used. Substitution of other sails shall not be permitted except in cases of extreme hardship and then only with the written permission of the Race Committee. In no circumstances shall a boat be permitted to use the sail number of another boat already competing.
- 19.4. Subject to the written permission of the Race Committee a boat chartered or loaned for the event may declare at the time of entry or registration a sail number to be displayed on all sails used in the regatta which may be different from the number of the boat as stated on the measurement certificate provided that this declared number shall not be the sail number of any other boat competing in the regatta.
- 19.5. In an emergency, or on a downwind leg of the course, the helmsman may hand over to a crew member who is not a member of the NSOA.

20. EQUIPMENT AND MEASUREMENT CHECKS

- 20.1. Boats may be checked before or after any race at the discretion of the Race Committee.

- 20.2. Before a boat is eligible to race, her current, valid measurement certificate must be presented at the Race Office. Only under exceptional circumstances will Rule 78.2 (Compliance with Class Rules; Certificates) be applied.
- 20.3. Each boat, with her sails and equipment, shall be available for inspection as stated in the Notice of Race.

21. ADVERTISING

- 21.1. The Championship sponsor advertising shall be displayed as per Addendum 4.0
- 21.2. In accordance with class rule C.4.1 Advertising on the boat chosen by the owner or person in charge is prohibited.

22. OFFICIAL BOATS

All Race Committee Vessels, including mark boats will display an orange flag when on station.

23. SUPPORT BOATS

Not applicable

24. ENVIRONMENT

No boat shall discharge rubbish into the water. Any boat observed doing so by a member of the Race Committee or protest committee may be protested.

25. HAUL-OUT RESTRICTIONS

As specified in NOR 15.

26. DIVING EQUIPMENT AND PLASTIC POOLS

Underwater breathing apparatus and plastic pools or their equivalent shall not be used between the preparatory signal of the first race and the end of the regatta.

27. RADIO COMMUNICATION

Except in an emergency, a boat shall neither make radio transmissions while racing nor receive radio communications not available to all boats. This restriction also applies to mobile phones. This instruction does not apply to any transmissions made for safety reasons or to advise the Race Committee of a boat's retirement. The channel may also be used by the Race Committee to inform boats of general matters relating to the racing. The channel to be used for such transmissions is **Channel 77**

28. PRIZES

As specified in NOR 19

29. NOT USED

NOT USED

30. INSURANCE

Each participating boat shall be insured with valid third-party liability insurance with a minimum cover of €2,000,000.00 (Two million Euro, or the equivalent Pound Sterling Pound) per event.

Addendum 1 Local Information & Timetable

A1.1 Official Notice Board

Notices to competitors will be posted on the official notice board(s) located in the covered archway at the entrance to Howth Yacht Club

A1.2 Signals Made Ashore

Signals made ashore will be displayed at on the flag pole at the top of the Marina entrance

A1.3 Schedule of Races

<i>Date</i>	<i>Event</i>	<i>Time/Warning Signal</i>
<i>Thursday 18th June</i>	<i>Registration</i>	<i>1800 – 2100</i>
	<i>Launching</i>	<i>0900 – 2000</i>
<i>Friday 19th June</i>	<i>Registration</i>	<i>1100 - 1600</i>
	<i>Launching</i>	<i>0900 - 1600</i>
	<i>Competitors' Briefing</i>	<i>1600</i>
	<i>Race 1 Warning Signal</i>	<i>1800</i>
<i>Saturday 20th June</i>	<i>Race Warning Signal</i>	<i>1055</i>
	<i>Subsequent races</i>	<i>Immediately after preceding races</i>
<i>Sunday 21st June</i>	<i>Race Warning Signal</i>	<i>1055</i>
	<i>Subsequent races</i>	<i>Immediately after preceding races</i>
	<i>Craning-out</i>	<i>1400 - 1900</i>

A1.4 Course Area

The Course area will be to the North of Howth Harbour. Depending on wind conditions, the start area could be up to four miles North of Howth Harbour. Details will be provided at the briefing

A1.5 Not used

Not used

A1.6 Hazards or Restrictions

Boats sailing from Howth Harbour to the race area are advised to stay to the East of the Spit Mark, a black conical mark, with the letter S in white. This mark is located at the eastern end of a sandbank.

A1.7 Safety Channel

The channel to be used for safety purposes or to advise the race committee of a boat's retirement is **77**

A1.8 Location of the Race Office

The Race Office is located in the room beside the Marina Office at Howth Yacht Club.

Addendum 2 Courses

The course to be sailed will be indicated by displaying the appropriate numeral pennant on the Committee Boat before the warning signal for the race. The displayed course may be changed prior to the warning signal, any such change shall be signaled by displaying Flag C accompanied by five sound signals. This changes Rule 27.1. Courses 1 and 2 are intended for use on single race days. Courses 3 and 4 are intended for use when there is more than one race programmed on the day.

The course configuration and the order of rounding marks will be as follows. In all cases Mark 1 is the intended windward mark.

Course No 1. Signified by - Numeral Pennant 1 Olympic Windward Leeward Triangle

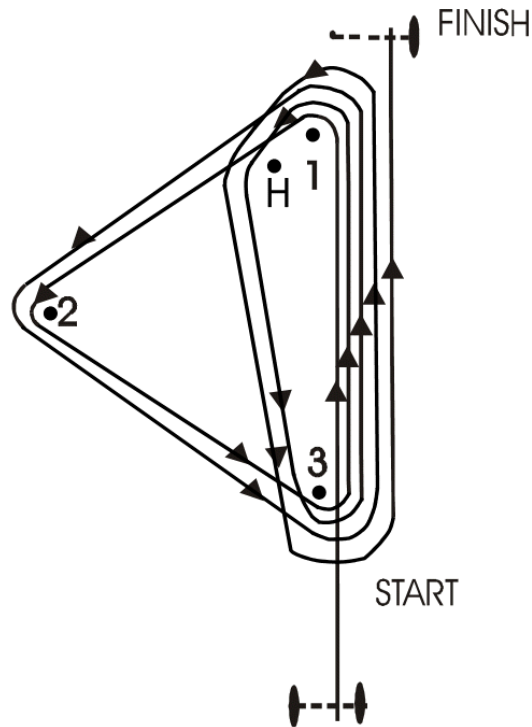

Start - 1 - 2 - 3 - 1 - H - 3 - 1 - 2 - 3 - 1 - H - 3 - Finish

Course No 2.
Signified by - Numeral Pennant 2
Windward Leeward with Gate

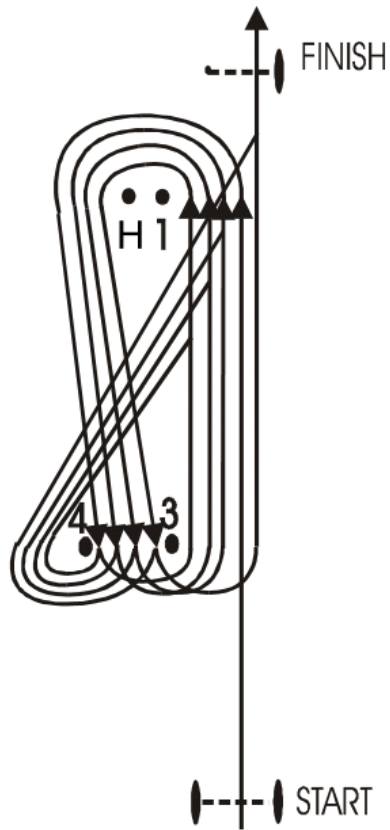

Start - 1 - H - 3or4 - 1 - H - 3or4 - 1 - H - 3or4 - 1 - H - 3or4 - Finish

**Course No 3.
Signified by - Numeral Pennant 3
Olympic Windward Leeward Triangle
Leeward Finish**

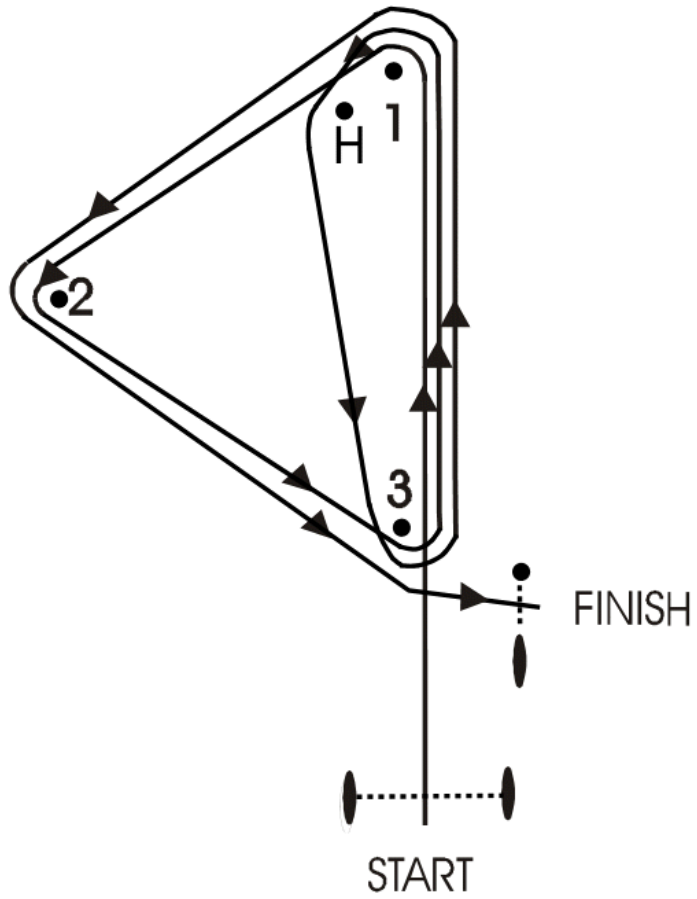

Start - 1 - 2 - 3 - 1 - H - 3 - 1 - 2 - 3 - Finish

**Course No 4.
Signified by - Numeral Pennant 4
Windward Leeward with Gate
Leeward Finish**

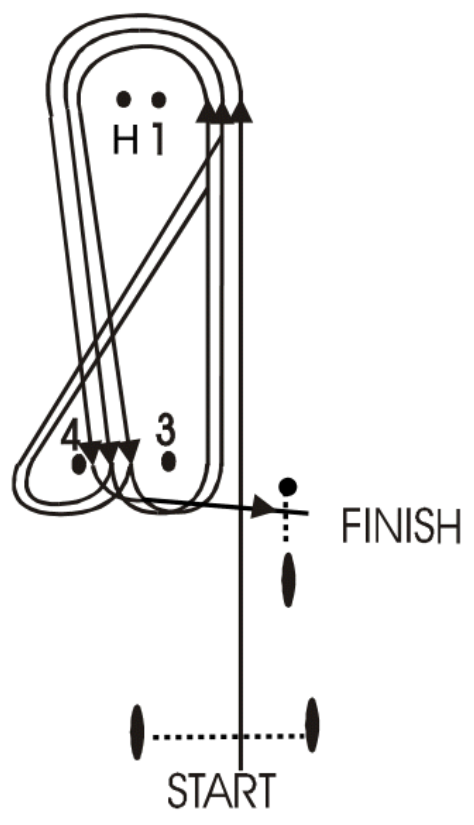

Start - 1 - H - 3or4 - 1 - H - 3or4 - 1 - H - 3 - Finish

Addendum 3 Description of Marks

A3.1 Marks 1, 2, 3 and 4 will be large black inflatable

The marks may bear the name of various sponsors.

A3.2 Mark H will be large black inflatable

A3.3 New marks, as provided in Sailing Instruction 12.1, will be large yellow inflatable

A3.4 The Starting Line will normally be between two committee boats. However, the port end committee boat may be substituted by a starting mark, which will be a tall orange mark.

A3.5 The Finishing Mark will be a Red Spherical Mark